

ML710_REC Recessed Paper Towel Dispenser & Waste Receptacle

Material Specifications

- #304 Stainless Steel
- Seamless Welds and Rolled Edges for Safety

Unit Includes

- Paper Towel Dispenser (350 C-fold paper towels or 475 Multi-fold paper towels)
- 6.5L Removable Stainless Steel Waste Container

Dimensions

- **Overall Size:** 365mmW x 720mmH x 112mmD
- **Wall Opening:** 325mmW x 685mmH x 105mmD

Installation Guidelines

- *May be subject to Australian Building Code Regulations for height and location fixing and may be subject to placement as per architectural drawings. In all cases, this is the responsibility of the installer.*
- *Fixings and anchors are not included with the units and are the responsibility of the installer to appropriately fix the unit to the wall.*

1. Cut out the recess in the wall using the wall opening dimensions above. Ensure that the unit position will maintain its functionality and does not interfere with the operation of any other objects.
2. Using the mounting hole dimensions on the drawing to measure and mark placement for the unit.
3. To access the mounting holes, open the unit door and align the rear fixing holes over marks and drill holes.
4. Using appropriate fixings, fit unit to the wall and loosely secure.
5. Check the unit is level and tighten fixings to finish installation.

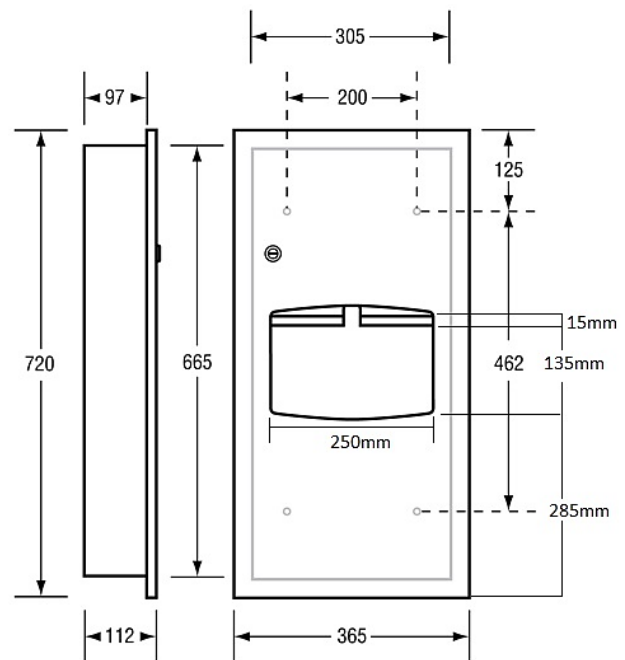

Features

- Unit fitted with security lock.
- Full length piano hinge on door.



This product is AS1428.1 compliant (accessible compliant) when installed in accordance with the guidelines.

The technical recommendations contained in this document are necessarily of a general nature and should not be relied on for specific applications without first securing competent advice. Whilst Metlam Australia Pty Ltd has taken all reasonable steps to ensure the information contained herein is accurate and current, it does not warrant the accuracy or completeness of the information and does not accept liability for errors or omissions. Any Commercial product should only be installed by a competent tradesperson and serviced/maintained by knowledgeable janitorial staff or competent people. Metlam Australia accepts no responsibility for any damage to product, walls or fixtures due to incorrect installation or maintenance of any of their products.

The photographs and line drawings of the products presented above are representational only.

Metlam Australia Pty Ltd reserves the right to, and from time to time, make changes and improvements in design and dimensions.

The photographs and line drawings of the products presented above are representational only.
Metlam Australia Pty Ltd reserves the right to, and from time to time, make changes and improvements in design and dimensions.